



SOLTECH

PRESSURE CONTROLS

REDUCING PRESSURE VALVES

[RG/RT-03,06,10]

※SPECIFICATION

MODEL	SIZE	MAX. PRES. MPa(Psi)	MAX. FLOW ℓ/min(GPM)	WEIGHT (Kg)	
				RT	RG
RG, RT	03	25 (3630)	50(13.2)	4.2	4.6
	06		125(33)	7.4	7.2

※GRAPHIC SYMBOL

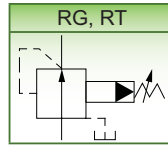

※MODEL NUMBER DESIGNATION

R	G	03	B	(90)
SERIES NO.	CONNECTION TYPE G: SUB-PLATE TYPE T: THREADED TYPE	VALVE SIZE 03: 3/8", ISO 5781-AG-06-2-A 06: 3/4", ISO 5781-AH-08-2-A	PRESSURE ADJ. RANGE MPa(psi) B:0.7~7(101.5~1015) C:3.5~14(507.5~2030) H:7~25(1015~3630)	DESIGN No. OMIT: DIN 912 BOLTS 90: UNC BOLTS (NORTH AMERICA)

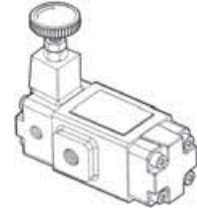

RT-03

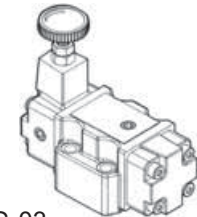

RG-03

※ACCESSORIES

MODEL	SOCKET HEAD SCREW CAP		O RING			
	European Design. Std.	N. America Design Std.				
RG-03	M10 × 50 Lg.	3/8-16 UNC × 2 Lg.	4 Pcs	P9	1 Pcs	P18 2 Pcs
RG-06	M10 × 50 Lg.	3/8-16 UNC × 2 Lg.	4 Pcs	P9	2 Pcs	P29 2 Pcs

※PRODUCTS LIST

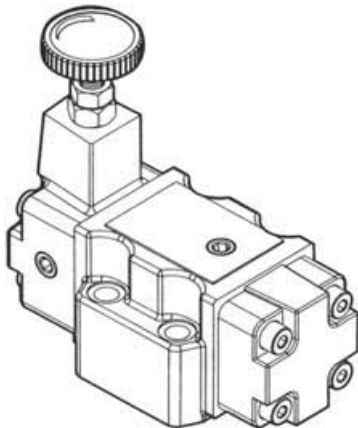

RG-03

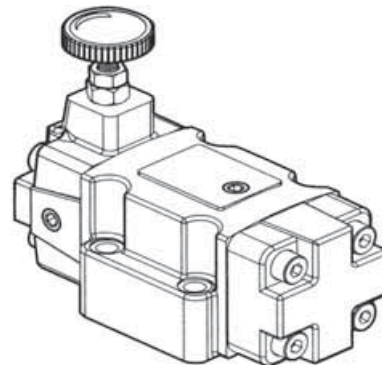

RG-06

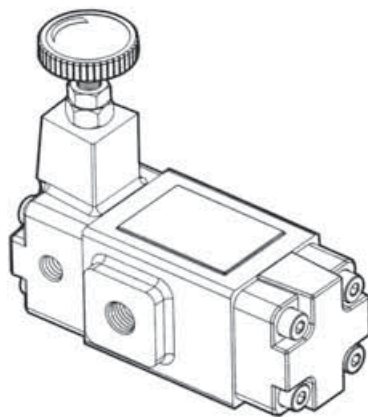

RT-03

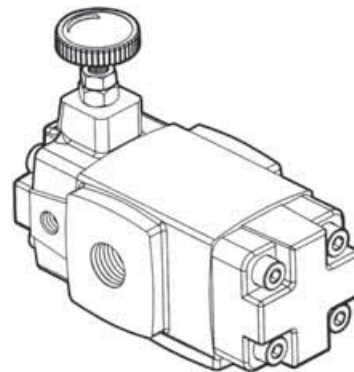

RT-06

C

RG-SERIES

DIMENSIONS

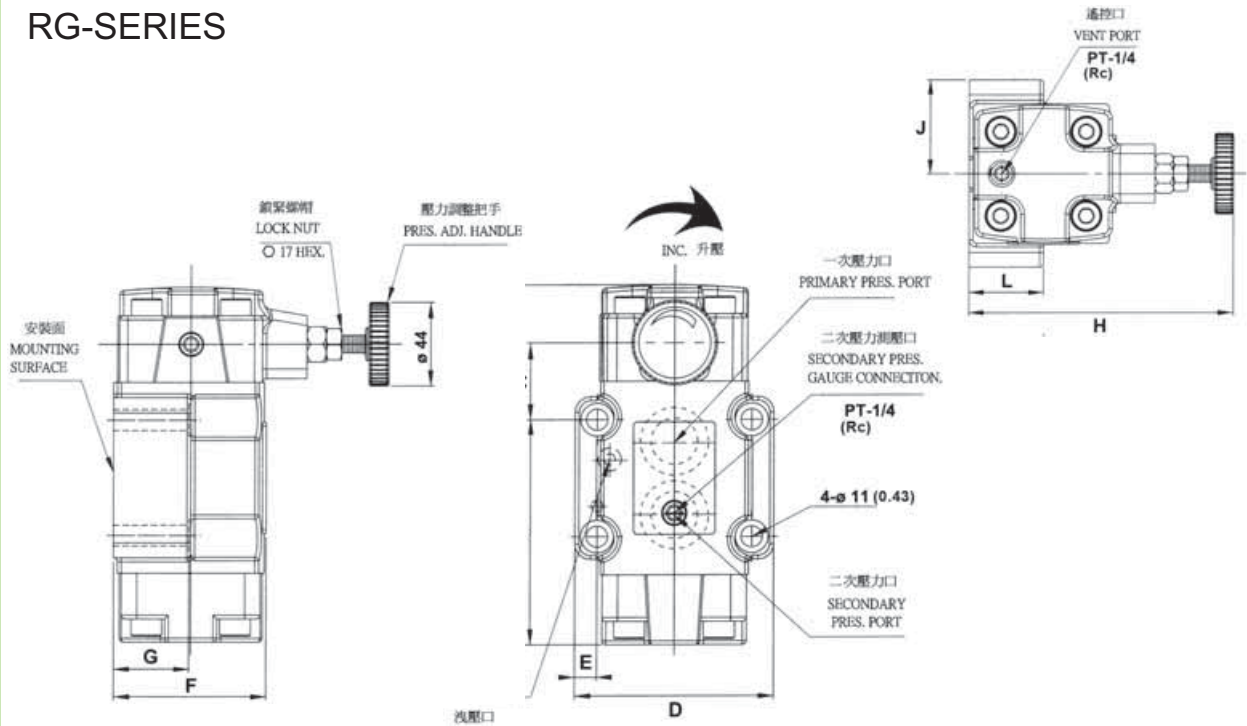

MODEL	A	B	C	D	E	F	G	H	I	J
RG-03	159(6.25)	93.5(3.68)	40.5(1.59)	89(3.50)	11.2(0.44)	69(2.71)	42(1.65)	145.5(5.72)	43(1.69)	44.5(1.75)
RG-06	186(7.32)	116.5(4.58)	40(1.57)	102(4.01)	11.3(0.44)	79(3.11)	39(1.53)	143(5.62)	40(1.57)	51(2.00)

UNIT: M.M.(INCHES)

DIMENSIONS

RT-SERIES

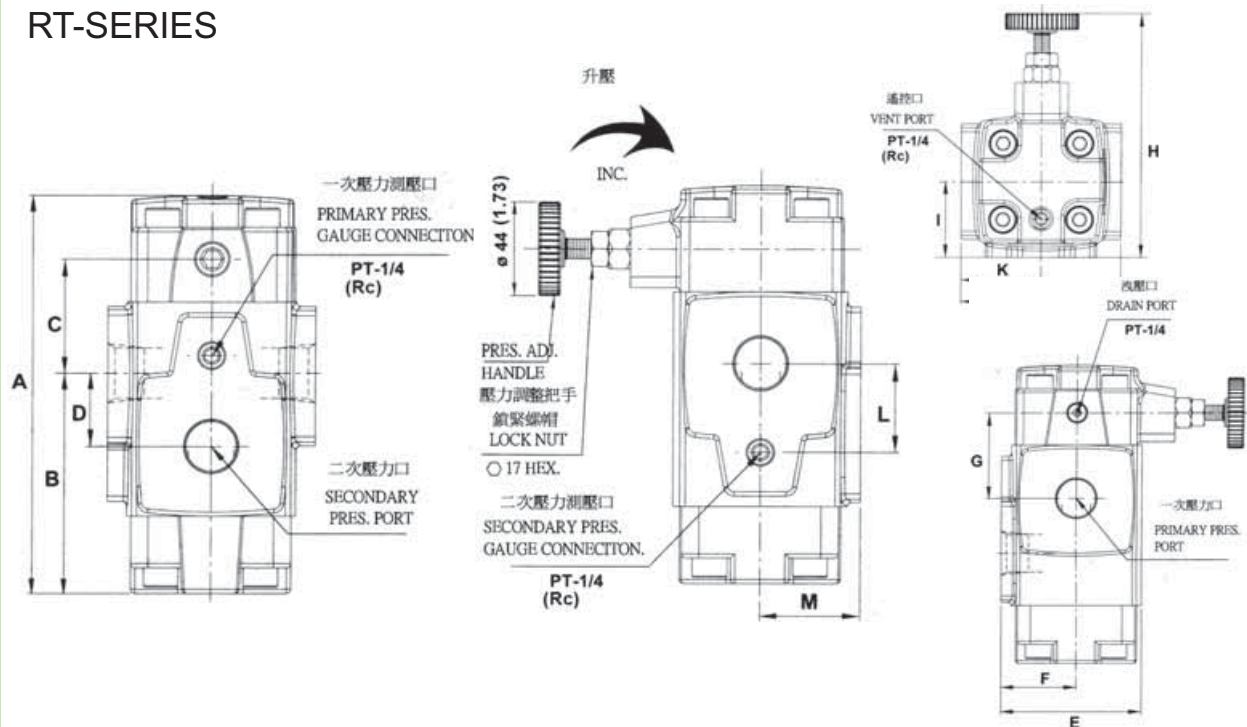

UNIT: M.M.(INCHES)

MODEL	A	B	C	D	E	F	G	H	I	J	K	L	M
RT-03	159(6.25)	86(3.38)	48(1.88)	30(1.18)	74(2.91)	41.5(1.63)	47(1.85)	151(5.94)	42(1.65)	80(3.14)	40(1.57)	30(1.18)	41.5(1.63)
RT-06	186(7.32)	103(4.05)	53(2.08)	34(1.33)	86(3.38)	46(1.81)	53(2.08)	148.5(5.84)	46(1.81)	96(3.77)	48(1.88)	42(1.65)	46(1.81)



SOLTECH

PRESSURE CONTROLS

REDUCING PRESSURE WITH CHECK VALVES

【RCG/RCT-03,06,10】

※SPECIFICATION

MODEL	SIZE	MAX. PRES. MPa(Psi)	MAX. FLOW ℓ/min(GPM)	WEIGHT (Kg)	
				RCT	RCG
RCG, RCT	03	25 (3630)	50(13.2)	4.5	5.5
	06		125(33)	7.8	8.2

※GRAPHIC SYMBOL

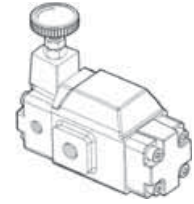
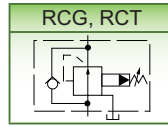

RCT-03

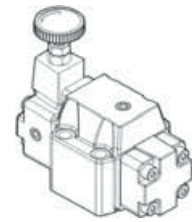

RCG-03

※MODEL NUMBER DESIGNATION

RC	G	03	B	(90)
SERIES NO. RC: REDUCING ADDED TO DESIGNATED INTEGRAL CHECK	CONNECTION TYPE G: SUB-PLATE TYPE T: THREADED TYPE	VALVE SIZE 03: 3/8", ISO 5781-AG-06-2-A 06: 3/4", ISO 5781-AH-08-2-A	PRESSURE ADJ. RANGE MPa(psi) B:0.7~7(101.5~1015) C:3.5~14(507.5~2030) H:7~25(1015~3630)	DESIGN No. OMIT: DIN 912 BOLTS 90: UNC BOLTS (NORTH AMERICA)

※ACCESSORIES

MODEL	SOCKET HEAD SCREW CAP				O RING					
	European Design. Std.	N. America Design Std.								
RCG-03	M10 × 75 Lg.	3/8-16 UNC × 2-3/4 Lg.	4	Pcs	P9	1	Pcs	P18	2	Pcs
RCG-06	M10 × 85 Lg.	3/8-16 UNC × 3-1/4 Lg.	4	Pcs	P9	2	Pcs	P29	2	Pcs

※PERFORMANCE CURVES

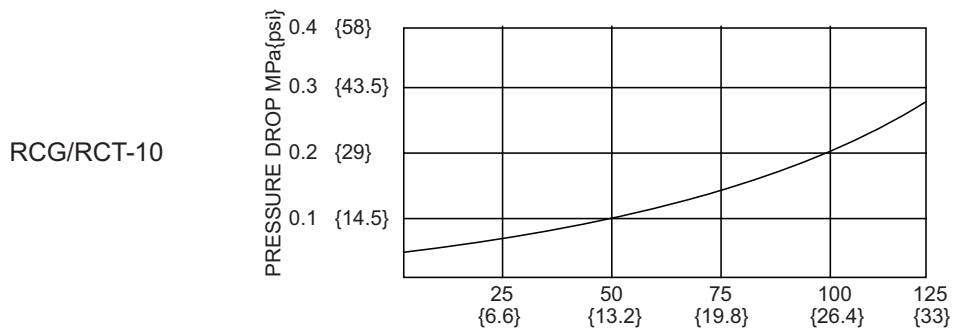
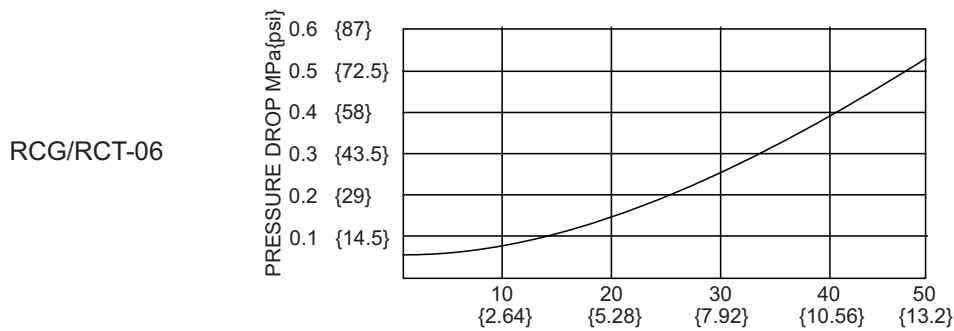
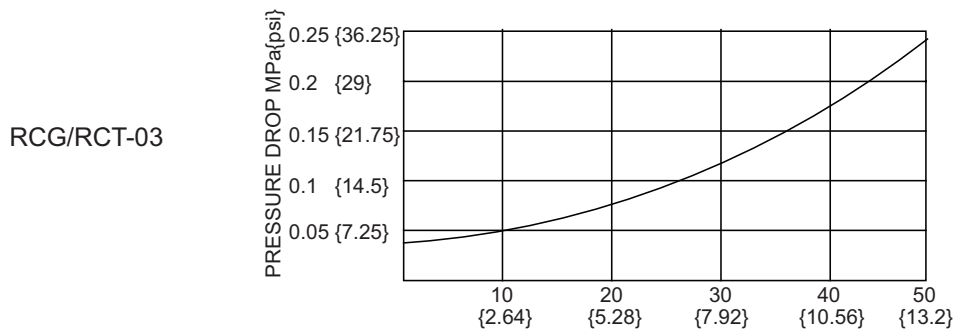

RCG-SERIES

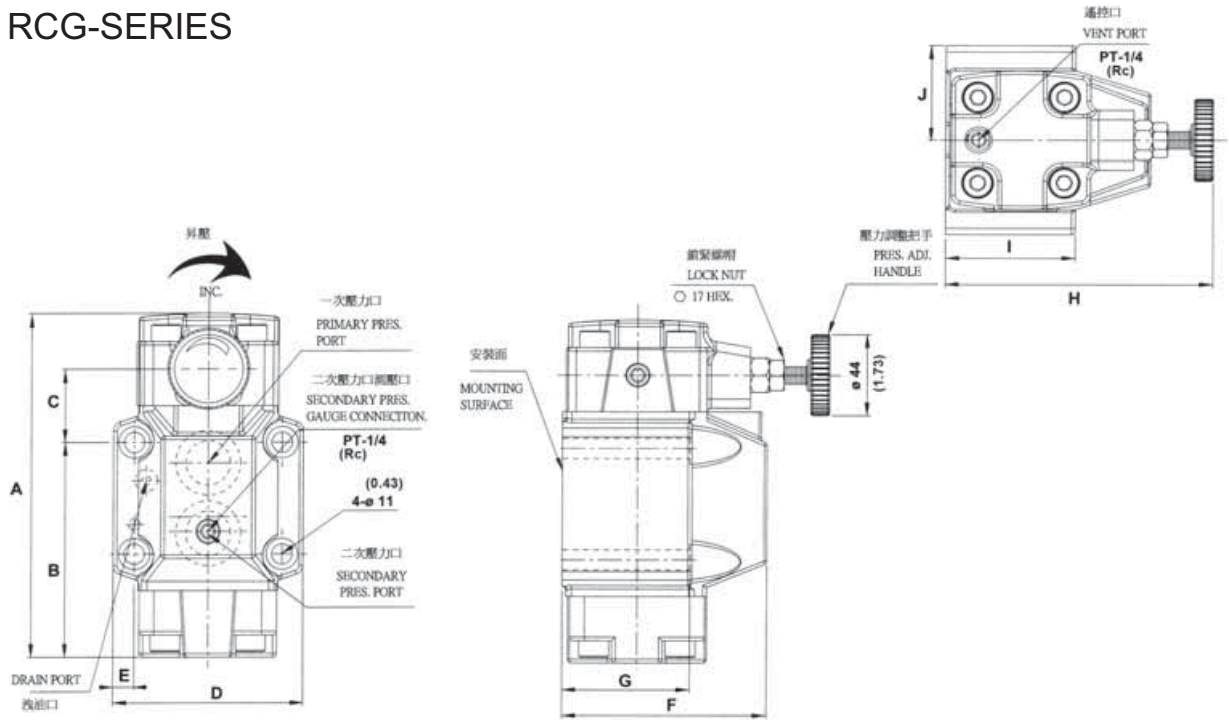

MODEL	A	B	C	D	E	F	G	H	I	J
RG-03	159(6.25)	93.5(3.68)	40.5(1.59)	89(3.50)	11.2(0.44)	69(2.71)	42(1.65)	145.5(5.72)	43(1.69)	44.5(1.75)
RG-06	186(7.32)	116.5(4.58)	40(1.57)	102(4.01)	11.3(0.44)	79(3.11)	39(1.53)	143(5.62)	40(1.57)	51(2.00)

UNIT: M.M.(INCHES)

DIMENSIONS

RCT-SERIES

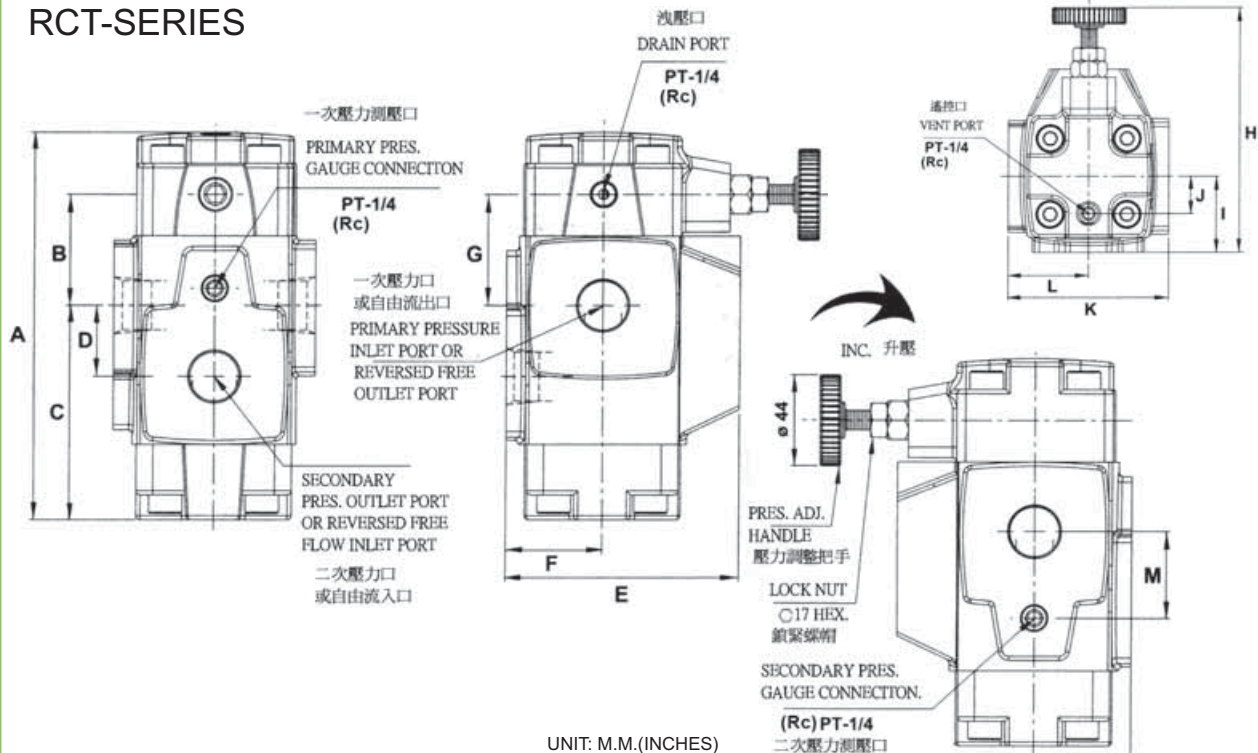

UNIT: M.M.(INCHES)

MODEL	A	B	C	D	E	F	G	H	I	J	K	L	M
RT-03	159(6.25)	86(3.38)	48(1.88)	30(1.18)	74(2.91)	41.5(1.63)	47(1.85)	151(5.94)	42(1.65)	80(3.14)	40(1.57)	30(1.18)	41.5(1.63)
RT-06	186(7.32)	103(4.05)	53(2.08)	34(1.33)	86(3.38)	46(1.81)	53(2.08)	148.5(5.84)	46(1.81)	96(3.77)	48(1.88)	42(1.65)	46(1.81)



SOLTECH

PRESSURE CONTROLS

MOUNTING INTERFACE

C

DIMENSIONS

BR-SERIES
BG-SERIES
DB-SERIES
SBG-SERIES

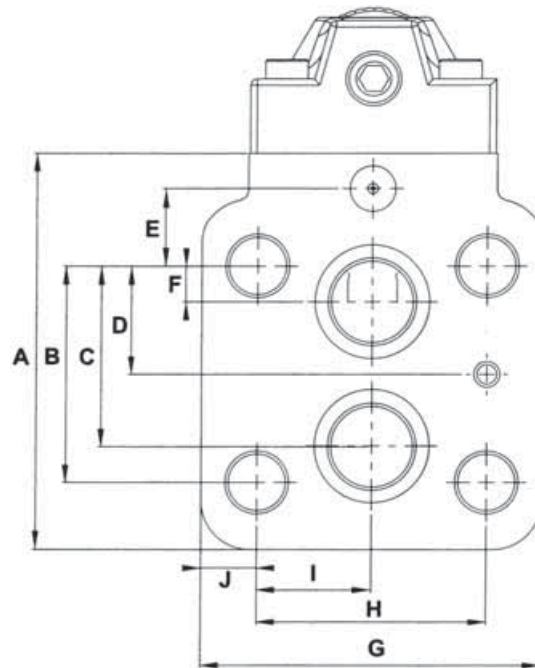

MODEL	A	B	C	D	E	F	G
03	53.8(2.11)	47.4(1.86)	22(0.86)	22(0.86)	0	53.8(2.11)	26.9(1.05)
06	66.7(2.62)	55.5(2.18)	33.4(1.31)	11(0.43)	23.8(0.93)	70(2.75)	35(1.37)
10	88.9(3.50)	76.2(3.00)	44.5(1.75)	12.7(0.50)	31.8(1.25)	82.6(3.25)	41.3(1.62)

UNIT: M.M.(INCHES)

DIMENSIONS

RG-03
HG-03
HCG-03
CPDG-03

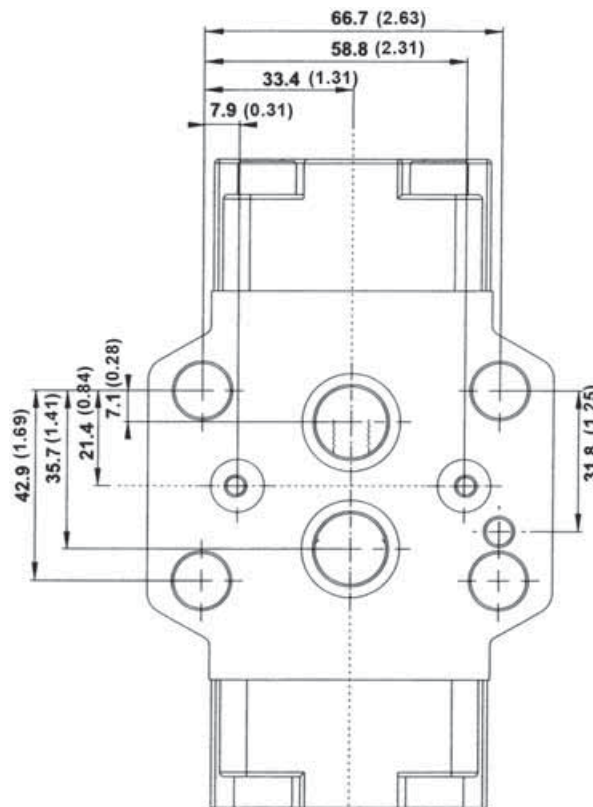

UNIT: M.M.(INCHES)



SOLTECH

PRESSURE CONTROLS

MOUNTING INTERFACE

RG-06
HG-06
HCG-06
CPDG-06

DIMENSIONS

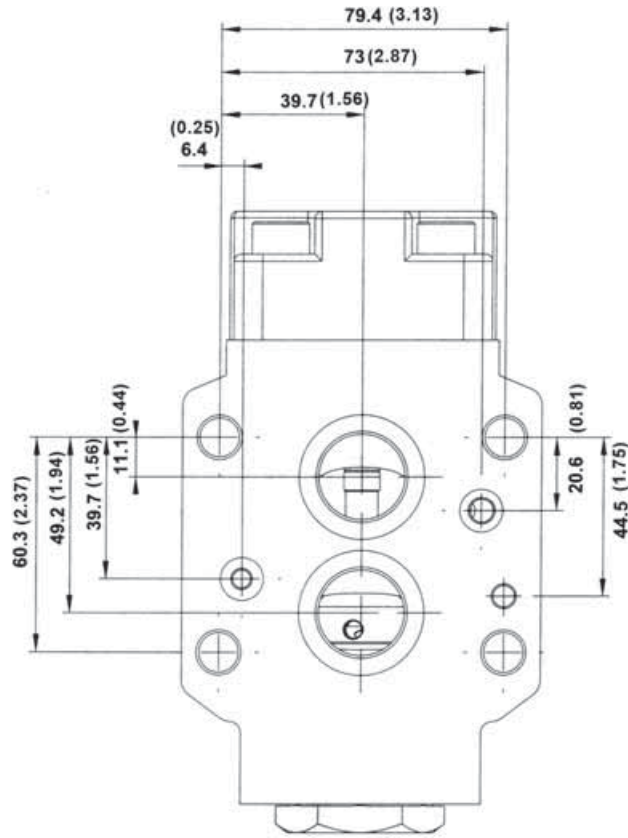

UNIT: M.M.(INCHES)

HG-10
HCG-10
CPDG-10

DIMENSIONS

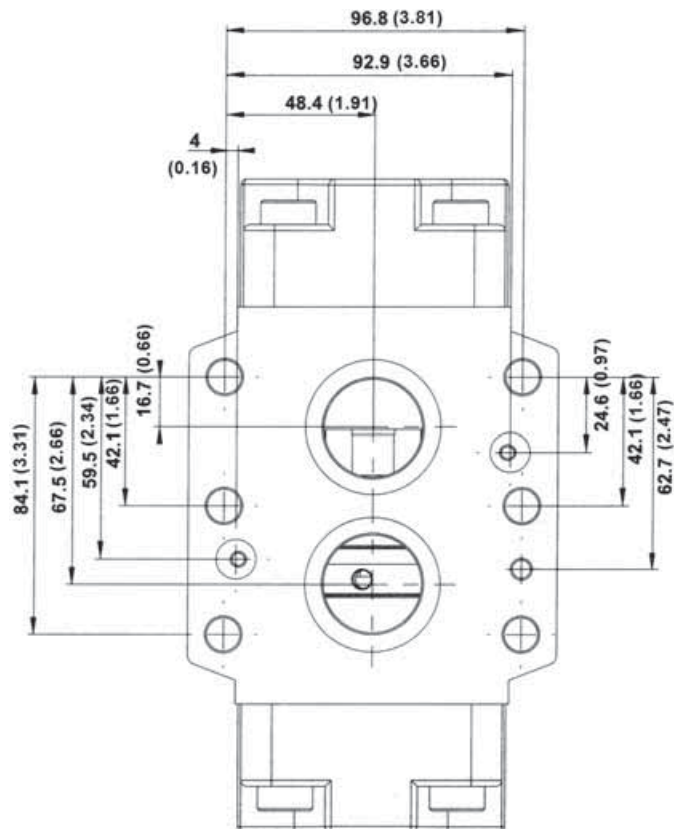

UNIT: M.M.(INCHES)

C